

PRODUCTS AND SERVICES FOR A SUSTAINABLE TUNNEL

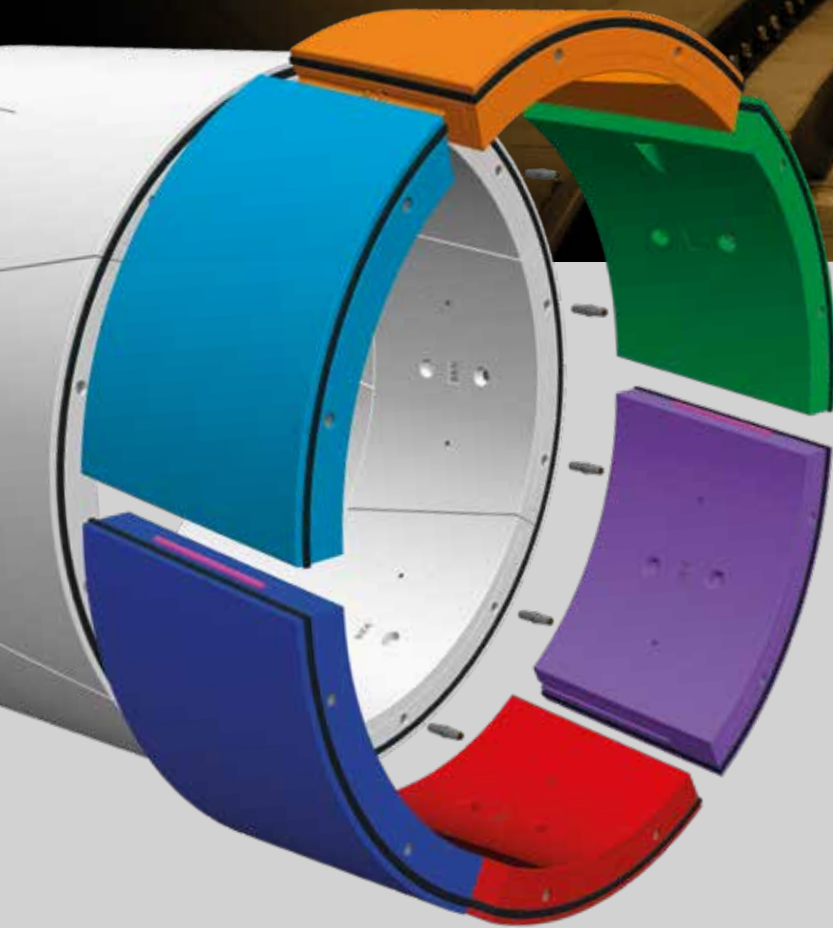

Sealing



Connection
and Accessories

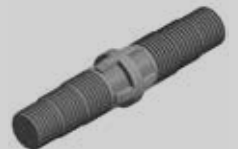

Precast Plant



Technical
Co-generation



FAMA
HIGH INTENSITY OF INNOVATION

Reputation | Competitiveness | Skills

info@famaspa.it | www.famaspa.it

Index

FAMA Profile	p.4
Sustainability	p.5
FAMA Time Line	p.6
FAMA Products	p.6
References	p.8
SEALING	p.12
FAMA Gasket Strength Elements	p.12
FAMA Soft Corner Technology	p.13
ANCHORED GASKETS	p.14
MIXED ANCHORED GASKETS	p.14
GLUED-IN GASKETS	p.15
MIXED GLUED-IN GASKETS	p.15
FAMA SPECIAL GASKETS	p.16
HYDROPHILIC GASKETS	p.16
INTRUSIVE GASKET	p.17
FAKE GASKET FOR TRIAL RING	p.17
ASYMMETRIC GASKET	p.18
CHEMICAL PROTECTION SYSTEM	p.18
GASKET PROTECTION SHIELD	p.19
CROSS GASKET	p.19
CONNECTION SYSTEMS AND ACCESSORIES	p.20
FAMA Connection Systems	p.20
FAMA Heeled Tooth Technology	p.21
SMARTBLOCK	p.22
SMARTBLOCK WITH BREAKAWAY	p.22
SCREW SMARTBLOCK	p.23
SCREW SMARTBLOCK WITH BREAKAWAY	p.23
SMARTBLOCK HS – CROSS PASSAGE	p.24
SMARTBLOCK FOR LAUNCHING RING	p.24
SMARTBLOCK FOR REMOVABLE SEGMENTS	p.24
SMARTBLOCK SELF-PROTECTED AGAINST AGGRESSIVE AGENTS	p.24
DEMOLDING FACILITATOR	p.25
CENTERING PINS	p.25
GROUTING AND LIFTING SYSTEMS	p.26
GROUTING AND LIFTING SYSTEMS WITH BREAKAWAY	p.27
THREADED SOCKETS DIN 405	p.28
BREAKAWAY SOCKETS	p.28
BREAKAWAY THREADED SOCKETS DIN 405	p.29
SOCKETS WITH METRIC THREAD ISO 261	p.30
RAIL SOCKET	p.30
STAINLESS STEEL FERRULE	p.30
SOCKET WITH METRIC THREAD FOR INJECTIONS	p.30
BREAKAWAY PLUG FOR SOCKET WITH METRICAL THREAD	p.30
SEALING PLUG	p.30
BOLTS AND WASHERS	p.31
SPECIAL BOLTS	p.31
GUIDING RODS	p.32
LOAD-SHARING CUSHIONS	p.33
PRECASTING PLANTS AND EQUIPMENT	p.34
FAMA Sizes and Designs Precast Plants	p.34
FAMA has the Expertise to Produce Formworks	p.35
FAMA Designs Plants for Carousel and Fixed Formwork	p.36
MECHANICAL SUPPORTS FOR BREAKAWAY ACCESSORIES	p.37
FORMWORK AND PLANTS	p.38
PRECAST EQUIPMENT	p.39
SPECIAL DEVICES	p.40
TECHNICAL COGENERATION	p.42
ANTI-SEISMIC DEVICE	p.42
CRACK INDUCER	p.43
PROTEX	p.43
TECHNICAL SUPPORT DOCUMENTATION	p.44
SPECIAL SERVICES	p.45
SCIENTIFIC COLLABORATIONS	p.47
CERTIFICATIONS AND ASSOCIATIONS	p.47

FAMA Profile

FAMA is the only company to provide a single business solution for precast tunnel lining segments. It provides molds, sealing gaskets and accessories manufactured by FAMA according to strict ISO 9001 quality standards. This means a **single technical reference for the complete tunnel lining project**.

From 1988 FAMA has been operating in the tunnel sector, initially as a subcontractor for large Italian companies; then, for over ten years, the company has focused on the design, study, development and testing of its own products to be placed directly on the market. FAMA has originally and autonomously contributed to innovation and about ten of its products have already been internationally recognized as deserving of industrial patent.

FAMA has collaborated with the most important technology transfer centers and universities and it fully complies with STUVA and AFTES recommendations, with the guidelines of ITA and other competence centers of the sector of tunnels.



FAMA has a **total area of 20.000 sqm, 10.000 sqm is covered area.**

- A factory for gasket production
- A factory for accessories production
- A warehouse for product storage

WITH ITS EXPERIENCE AS A MANUFACTURER
FAMA HAS TAKEN ITS STRENGTH AND AWARENESS
TO STUDY VERY EFFICIENT SOLUTIONS AT LOW COST

Sustainability

To preserve the planet, concrete and rapid actions occur, such as those planned in the UN Global Agenda for Sustainable Development.

Production and use of renewable energy, energy savings, regeneration of production waste and recovery of products from differentiated waste disposal, fostering diversity in order to promote a culture of inclusion in a world market where variety contributes to the creation of value, these are the concrete actions taken by FAMA which has always pursued a sustainable business model.

FAMA aims to promote the transition from a direct and extractive economy to a **regenerative and circular economy**.

FAMA attaches to all its offers a document on the environmental impact assessment. It illustrates the savings of carbon dioxide emission and water that result from the measures adopted.



EPD CERTIFICATION

FAMA commitment to environmental sustainability is certified by the EPD (Environmental Product Declaration) which accompanies its products and offers detailed, credible and verifiable information on the environmental performance of their life cycle.



FAMA Time Line

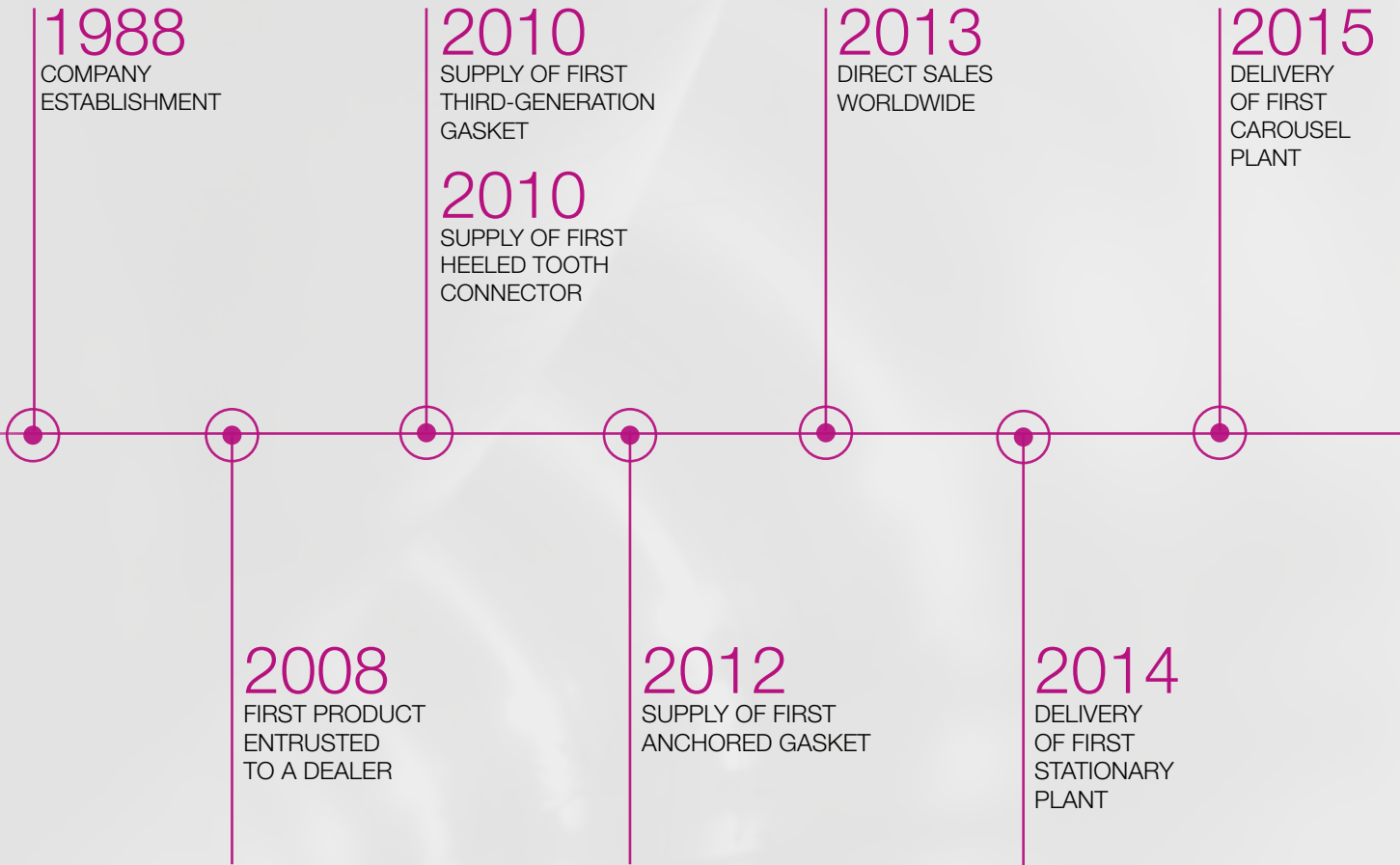

FAMA Products

106
TUNNELS

25+
COUNTRIES
OVER THE 5
CONTINENTS

+1.270
KM OF TUNNEL

2019

AFTES
AVIS D'EXPERTS

2023

DOUBLING
OF PRODUCTION
FACILITIES

2025

CETU AVIS
TECHNIQUE

2016

DELIVERY OF FIRST
ANTI-SEISMIC DEVICE

2022

DIGITALIZED
PROCESS CONTROL

2024

FRIULIA, FINANCIAL
INSTITUTION OF
FRIULI VENEZIA GIULIA
REGION, ENTERS
THE CAPITAL
STRUCTURE

860+

KM OF SEALED
TUNNEL

840+

KM OF CONNECTED
TUNNEL

References

N.	YEAR	PROJECT	COUNTRY	TUNNEL TYPE	TUNNEL EXTERNAL DIAMETER	TUNNEL LENGTH (M)
1	2008	ROME METRO B1	Italy	Metro	6.500 mm	6.080
2	2010	SURUÇ WATER TUNNEL	Turkey	Hydraulic	7.600 mm	4.480
3	2010	QUEJIGARES TUNNEL, GRANADA	Spain	Railway	8.900 mm	2.900
4	2010	PANDO TUNNEL	Panama	Hydroelectric	3.500 mm	5.160
5	2010	MONTE LIRIO TUNNEL	Panama	Hydroelectric	3.700 mm	7.880
6	2011	EL ALTO HEADRACE TUNNEL	Panama	Hydroelectric	6.800 mm	3.240
7	2011	KISHANGANGA HEADRACE TUNNEL	India	Hydroelectric	5.900 mm	14.630
8	2011	RAILWAY TO JERUSALEM, LINE C	Israel	Railway	9.700 mm	23.200
9	2012	CITYRINGEN METRO TUNNEL, COPENHAGEN	Denmark	Metro	5.500 mm	28.140
10	2012	SCILLA TUNNEL, REGGIO CALABRIA	Italy	Cable	3.800 mm	2.760
11	2013	EVERGREEN LINE, VANCOUVER	Canada	Metro	9.540 mm	1.950
12	2013	DIAMOND HILL TO KAI TAK TUNNELS, HONG KONG	China	Metro	7.100 mm	1.540
13	2013	MILAN METRO 4 EXPO LINE, (LORENTEGGIO-LINATE)	Italy	Metro	6.060 mm	6.450
14	2014	XE-PIAN XE-NANMOY TUNNEL	Laos	Hydroelectric	5.500 mm	11.800
15	2014	RIYADH METRO, LINE 3	Saudi Arabia	Metro	9.800 mm	4.600
16	2014	RED LINE NORTH UNDERGROUND, DOHA	Qatar	Metro	6.770 mm	22.800
17	2014	CALTANISSETTA, PORTO EMPEDOCLE TUNNEL	Italy	Road	14.650 mm	7.800
18	2014	TERZO VALICO DEI GIOVI, FINESTRA POLCEVERA	Italy	Railway	9.450 mm	1.800
19	2014	AL HAER WASTEWATER CONVEYOR, RIYADH	Saudi Arabia	Sewage	3.440 mm	11.900
20	2015	THESSALONIKI METRO, LINE 1 (BASE LINE)	Greece	Metro	5.900 mm	3.600
21	2015	TURIN METRO, SOUTH EXTENSION	Italy	Metro	7.480 mm	1.820
22	2015	NODO DI PALERMO TUNNEL	Italy	Metro	9.070 mm	2.175
23	2015	TURIN-LYON, ST. MARTIN DE LA PORTE	France	Railway	10.800 mm	8.740
24	2015	VISHNUGAD HEADRACE TUNNEL	India	Hydraulic	9.500 mm	12.300
25	2015	BRENNER BASE TUNNEL, H33 TULFES-PFONS	Austria	Railway	7.900 mm	15.080
26	2016	CATANIA METRO, LINE NESIMA - MONTE PO	Italy	Metro	10.240 mm	1.760
27	2016	TERZO VALICO DEI GIOVI, RADIMERO AND SERRAVALLE	Italy	Railway	9.400 mm	34.350
28	2016	FORRESTFIELD AIRPORT LINK	Australia	Metro	6.770 mm	14.400
29	2016	MILAN METRO 4 (BLUE LINE), EAST LINE	Italy	Metro	6.060 mm	3.730
30	2016	MILAN METRO 4 (BLUE LINE), WEST LINE	Italy	Metro	6.400 mm	6.150
31	2016	THESSALONIKI METRO, KALAMARIA EXTENSION	Greece	Metro	5.900 mm	7.200
32	2016	DESARROLLO SUSTENTABLE DE LA CUENCA MATANZA-RIACHUELO, LOT 1	Argentina	Hydraulic	3.600 mm	9.600
33	2016	FOLLO LINE, OSLO	Norway	Railway	9.550 mm	36.100
34	2017	ANGAT WATER TRANSMISSION	Philippines	Hydraulic	4.700 mm	6.500
35	2017	DUBAI METRO 2020	United Arab Emirates	Metro	9.300 mm	2.500
36	2017	MILAN METRO 4 (BLU LINE), CENTER LINE	Italy	Metro	8.850 mm	8.500
37	2017	DESARROLLO SUSTENTABLE DE LA CUENCA MATANZA-RIACHUELO, LOT 3	Argentina	Hydraulic	4.900 mm	12.040
38	2017	ABBASSAMENTO DEL CORRIDOR CABALLITO-MORENO, SARMIENTO	Argentina	Railway	11.120 mm	6.660
39	2017	CATANIA METRO LINE STESICORO-AEROPORTO	Italy	Metro	10.240 mm	1.875
40	2018	DESVIO COLECTOR DE LA BAJA COSTANERA RIACHUELO	Argentina	Sewage	5.000 mm	5.400

N.	YEAR	PROJECT	COUNTRY	TUNNEL TYPE	TUNNEL EXTERNAL DIAMETER	TUNNEL LENGTH (M)
41	2018	DOHA OUTFALL TUNNEL	Qatar	Hydraulic	4.140 mm	10.130
42	2018	DUBAI STORM WATER	United Arab Emirates	Hydraulic	10.700 mm	10.300
43	2018	NOVALICHES-BALARA AQUEDUCT 4, MANILA	Philippines	Hydraulic	3.500 mm	7.220
44	2018	ALGIERS METRO, LINE 1	Algeria	Metro	10.200 mm	8.450
45	2018	NORTHEAST BOUNDARY TUNNEL, WASHINGTON DC	USA	Hydraulic	7.720 mm	8.140
46	2018	ROME METRO C	Italy	Metro	6.400 mm	5.320
47	2018	RIO SUBTERRANEO DE LOMAS	Argentina	Hydraulic	4.400 mm	13.600
48	2019	BRENNER BASE TUNNEL, EXPLORATORY TUNNEL	Italy	Railway	6.420 mm	13.930
49	2019	BRENNER BASE TUNNEL, LOT MULES 2-3	Italy	Railway	10.170 mm	63.000
50	2019	GRAND PARIS, L14S GCO4	France	Metro	8.450 mm	4.055
51	2019	LYON METRO, LINE B EXTENSION	France	Metro	9.350 mm	2.260
52	2019	PUNE METRO, LINE 1	India	Metro	6.350 mm	8.960
53	2019	WARSAW METRO, LINE 2	Poland	Metro	6.000 mm	9.660
54	2020	CENTRAL INTERCEPTOR TUNNEL, AUCKLAND	New Zealand	Sewage	5.155 mm	14.400
55	2020	CENTRAL KOWLOON ROUTE, HONG KONG	China	Road	6.830 mm	790
56	2020	CITY RAIL LINK, AUCKLAND	New Zealand	Railway	6.840 mm	3.260
57	2020	COASTAL ROAD, MUMBAI	India	Road	11.750 mm	4.140
58	2020	LONATO TUNNEL	Italy	Railway	9.700 mm	9.300
59	2020	GRAND PARIS, LINE 16 LOT 2	France	Metro	9.500 mm	10.760
60	2020	KERENZERBERG TUNNEL	Switzerland	Railway	6.770 mm	4.735
61	2020	PALERMO-CATANIA-MESSINA, LINE FIUMETORTO-CEFALÙ-CASTELBUONO	Italy	Railway	9.600 mm	13.400
62	2020	LOS ANGELES OUTFALL	USA	Road	6.096 mm	11.200
63	2020	LIMA METRO, LINE 2	Peru	Metro	9.900 mm	22.100
64	2020	RTE MESIL, PARIS	France	Cable	3.600 mm	2.400
65	2020	SHIP CANAL WATER SEATTLE	USA	Hydraulic	6.298,8 mm	4.250
66	2020	SNOWY HYDRO 2.0	Australia	Hydraulic	10.660 mm	29.100
67	2020	ŚWINOUJŚCIE TUNNEL	Poland	Road	13.000 mm	1.485
68	2020	T2 TRUNK ROAD, HONG KONG	China	Road	13.500 mm	4.840
69	2020	MULARROYA TUNNEL	Spain	Hydraulic	3.300 mm	12.630
70	2020	HANOI METRO, CP03	Vietnam	Metro	6.300 mm	5.230
71	2021	EDAR SINOVA TUNNEL, SORIA	Spain	Hydraulic	3.600 mm	4.960
72	2021	DRAINAGE TUNNEL, LISBON	Portugal	Hydraulic	6.100 mm	5.500
73	2021	WAKRAH & WUKAIR, DRAINAGE TUNNEL, DOHA	Qatar	sewage	5.605 mm	13.200
74	2021	NAPOLI-BARI, APICE-HIRPINIA, ROCCHETTA TUNNEL	Italy	Railway	11.800 mm	6.500
75	2021	NAPOLI-BARI, APICE-HIRPINIA, GROTTAMINARDA AND MELITO TUNNELS	Italy	Railway	12.100 mm	6.400
76	2021	PAKAL DUL TUNNEL	India	Hydroelectric	8.000 mm	15.360
77	2021	SURAT METRO	India	Metro	6.350 mm	5.175
78	2021	MUMBAI METRO, LINE 9	India	Metro	6.350 mm	3.775
79	2022	FORTEZZA-PONTE GARDENA, FORCH DESCENT	Italy	Railway	10.700 mm	1.415
80	2022	SYDNEY METRO WEST, WESTERN TUNNELING PACKAGE	Australia	Metro	6.720 mm	17.130

N.	YEAR	PROJECT	COUNTRY	TUNNEL TYPE	TUNNEL EXTERNAL DIAMETER	TUNNEL LENGTH (M)
81	2022	PALERMO-CATANIA-MESSINA, GIAMPILIERI-FIUMEFREDDO LINE TAORMINA-GIAMPILIERI	Italy	Railway	9.000 mm 8.800 mm	44.000
82	2022	ISPARTAKULE HALKALI RAILWAY LINK	Turkey	Railway	8.200 mm	12.250
83	2023	BRASOV-SIMERIA, LOT 2 APATA-CATA	Rumania	Railway	9.400 mm	23.800
84	2023	ATHENS METRO, LINE 4 PHASE A	Greece	Metro	9.180 mm	11.400
85	2023	BRENNER BASE TUNNEL, H41 BAULOS SILLSCHLUCHT-PFONS	Austria	Railway	9.840 mm	16.500
86	2023	METRO TOULOUSE, LINE C, LOT 1 AND LOT 2	France	Metro	9.300 mm	12.100
87	2023	FLOOD CONTROL TUNNEL, BISAGNO RIVER, GENOA	Italy	Hydraulic	10.500 mm	5.965
88	2023	MEDIAN COLLECTOR (IDROPOLITANA), TURIN	Italy	Hydraulic	3.800 mm	9.600
89	2023	FORTEZZA-PONTE GARDENA, LOT 1	Italy	Railway	9.300 mm	39.825
90	2023	TRENTO RAIL BYPASS, LOT 3A	Italy	Railway	9.300 mm	21.000
91	2024	THANE-BORIVALI TUNNEL, PKG1&2	India	Road	2.890 mm	20.900
92	2024	GOREGAON MULUND LINK ROAD (GMLR)	India	Road	14.100 mm	9.400
93	2024	PALERMO-CATANIA-MESSINA, CALTANISSETTA XIRBI-NUOVA ENNA , LOT 4A	Italy	Railway	9.000 mm	41.050
94	2024	PALERMO-CATANIA-MESSINA, ENNA-DITTAINO LOT 4B	Italy	Railway	8.900 mm	14.565

FAMA Worldwide

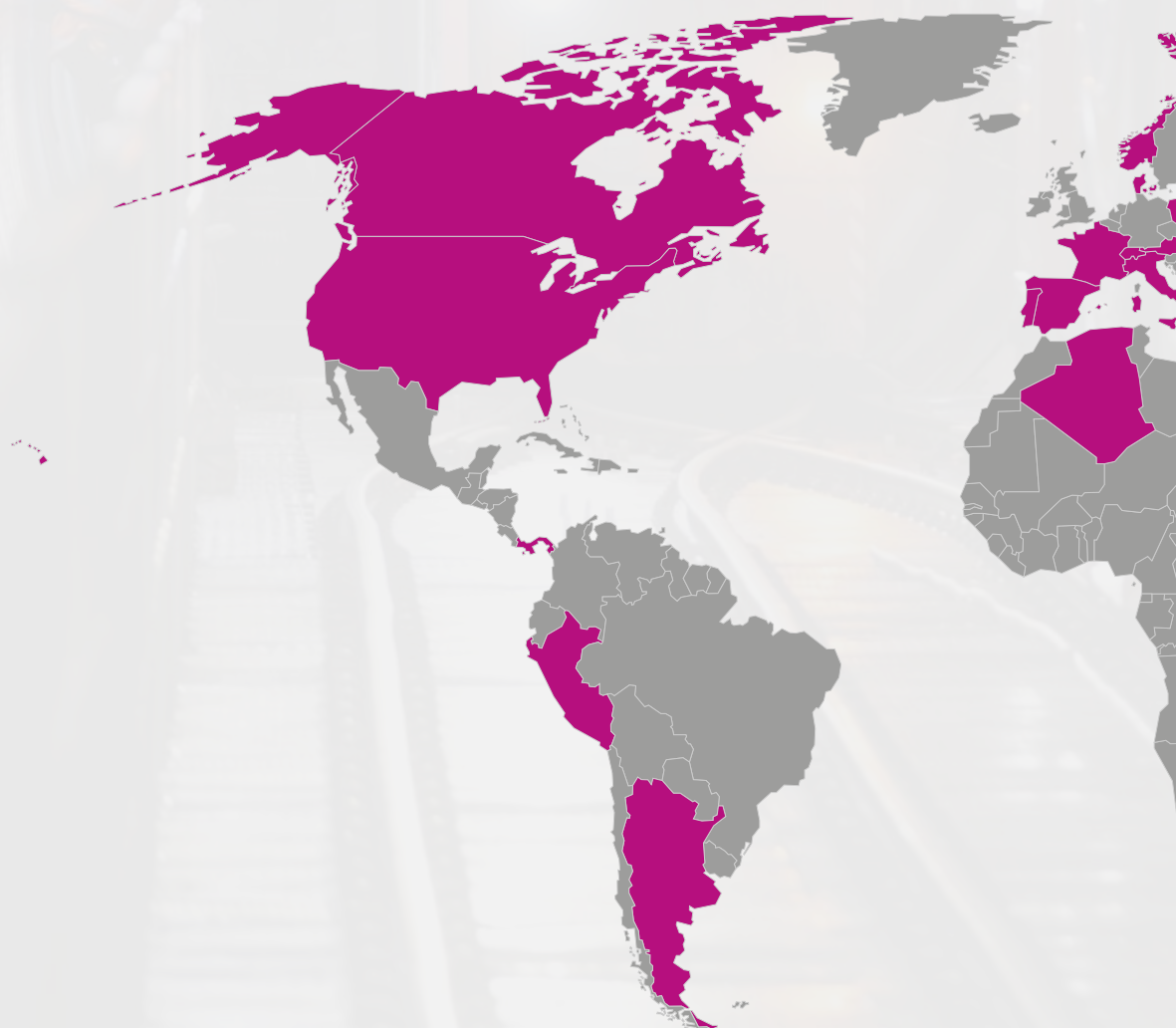

N.	YEAR	PROJECT	COUNTRY	TUNNEL TYPE	TUNNEL EXTERNAL DIAMETER	TUNNEL LENGTH (M)
95	2024	NAPOLI-BARI, ORSARA-BOVINO	Italy	Railway	9.400 mm	18.620
96	2024	NAPOLI-BARI, HIRPINIA-ORSARA	Italy	Railway	9.400 mm	53.100
97	2024	METRO CATANIA EXTENSION, MISTERBIANCO-PATERNÒ	Italy	Metro	10.300 mm	3.200
98	2024	NEOM TIME TRAVEL TUNNEL	Saudi Arabia	Railway	7.500 mm	7.875
99	2024	SALERNO-REGGIO CALABRIA, LOT 1A BATTIPAGLIA-ROMAGNANO AND INTERCONNECTION LS, BATTIPAGLIA-POTENZA	Italy	Railway	13.000 mm 9.600 mm	13.140
100	2024	CAMPOLATTARO RESERVOIR	Italy	Hydraulic	5.000 mm	7.550
101	2024	PALERMO-CATANIA-MESSINA, FIUMETORTO-LERCARA DIRAMAZIONE, LOTS 1+2	Italy	Railway	9.000 mm	39.715
102	2024	PALERMO-CATANIA-MESSINA, LERCARA DIRAMAZIONE-CALTANISSETTA XIRBI, LOT 3	Italy	Railway	8.900 mm 9.000 mm	33.720
103	2024	RAIL LINE 104	Poland	Railway	10.600 mm 4.500 mm	7.400
104	2024	OSMANELI-BURSA-BANDIRMA LINE	Turkey	Railway	8.200 mm	7.680
105	2025	MARICA ADIT TUNNEL	Australia	Hydraulic	11.260 mm	2.860
106	2025	BARCELONA METRO, LINE 8	Spain	Railway	10.240 mm	3.750

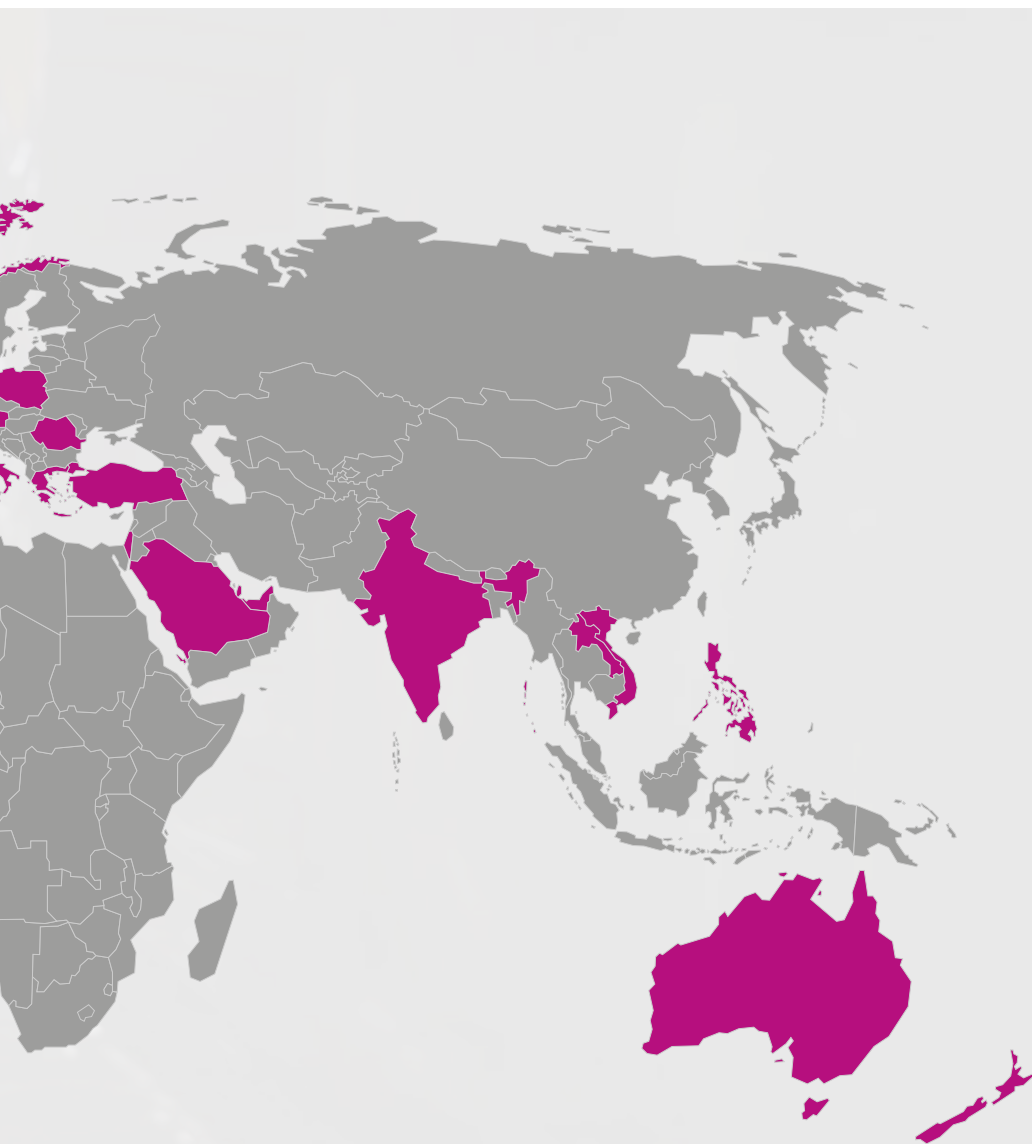

SEALING

FAMA Gasket Strength Elements

Integration system into formwork that makes quicker, easier and precise gasket positioning

Internal design of third generation that allows gasket compression thanks to the elongation of the meniscus

Anchorage system into concrete which is currently the best available for its tear resistance

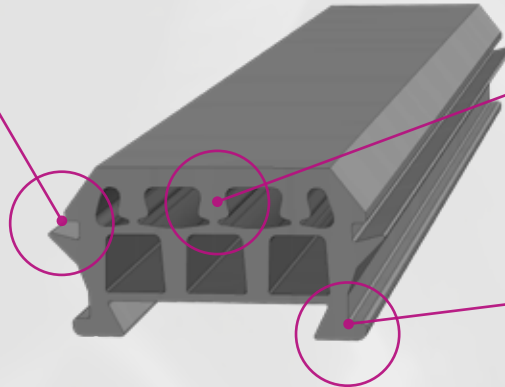

COMPARISON OF CONCRETE ANCHORAGE LOADS AND GASKET INTEGRATION TO FORMWORK

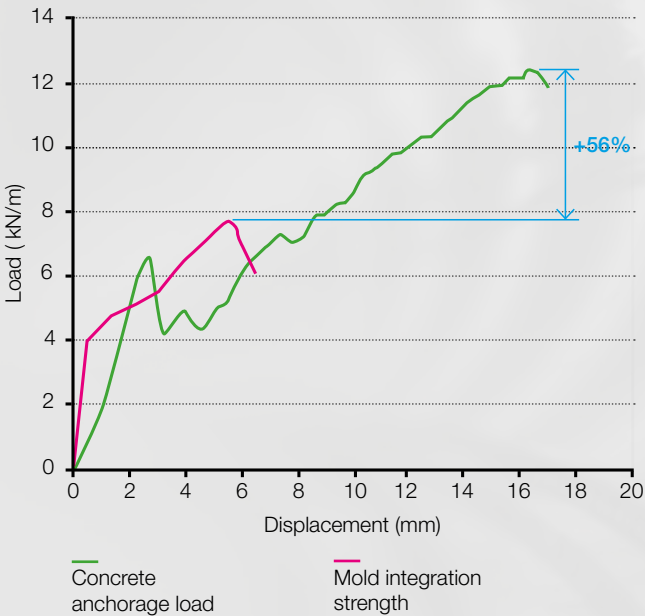

EXPERIMENTAL VIRTUALIZATION

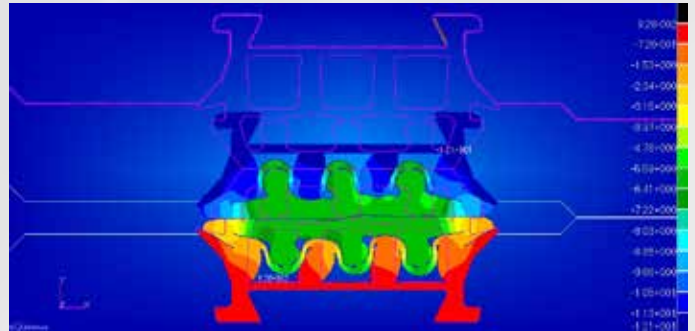

FAMA develops the shape of its profiles through intensive use of virtualization (MSC Marc software), which allows the profile to be designed and its characteristics determined, reducing the time of production.

As seen, the gasket exhibits excellent compressive reaction properties and a good level of sta-

bility, which, according to FAMA experience, is a necessary condition for good hydraulic sealing performance.

FAMA has supplied anchored gaskets in many large works for several hundred kilometers of tunnels.

FAMA Soft Corner Technology

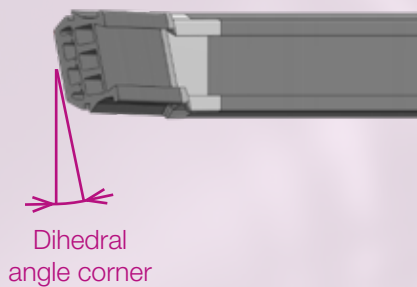
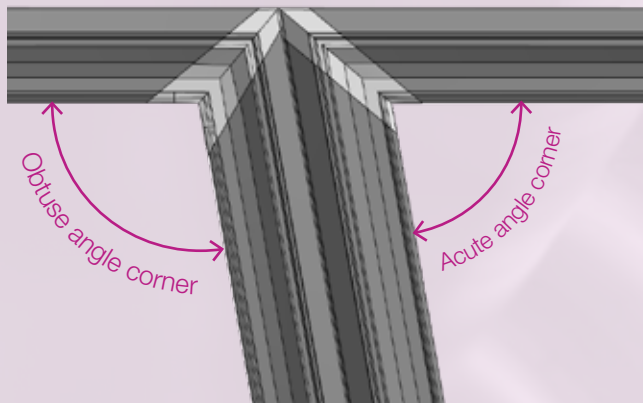

Compressive force of FAMA Soft Corner compared to other corners on the market

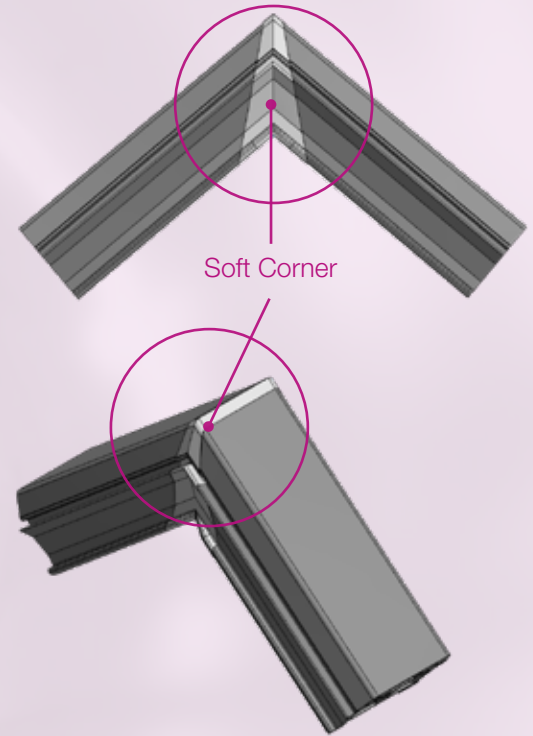

COMPARISON OF THE COMPRESSIVE FORCE BETWEEN THE CORNERS OF THE ANCHORED GASKETS

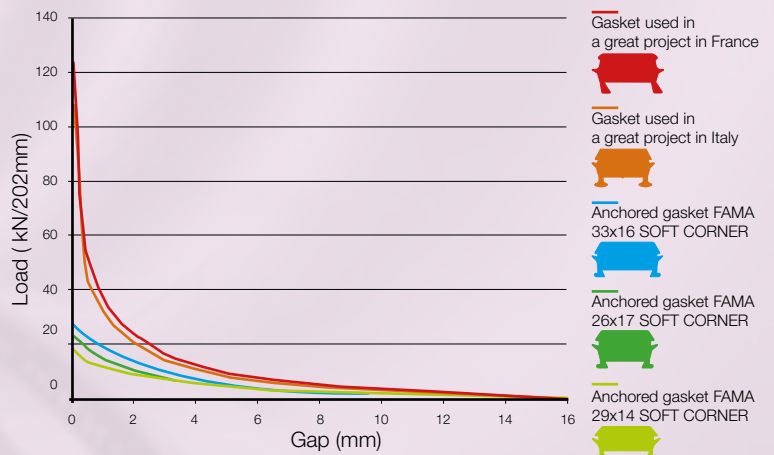

FAMA has designed, certified, produced and successfully used the special Soft Corner to minimize loads and preserve the segment corners from breakage.

FAMA corners are manufactured with innovative technologies and automation. Thus, they perfectly match the segments for a better sealing.

ANCHORED GASKETS

UG046
26 x 11

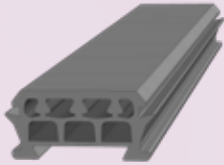

UG066
26 x 17

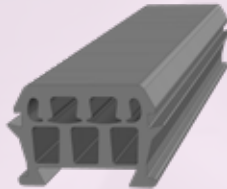

UG018
29 x 14

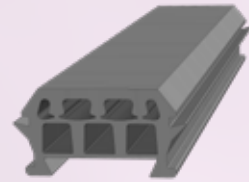

UG016
33 x 16

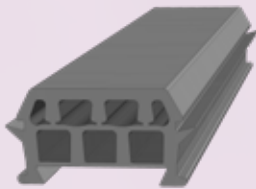

UG048
33 x 17



UG020
44 x 20

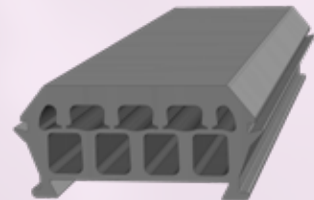

MIXED ANCHORED GASKETS With Hydrophilic Barrier

UG027
26 x 17

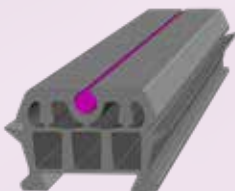

UG037
29 x 14

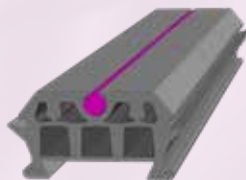

UG059
33 x 16

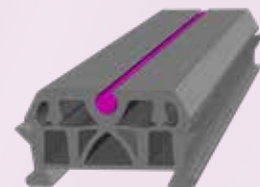

UG054
33 x 20

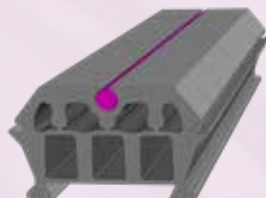

Each gasket can be customized according to the technical requirements of pressure and compressive load force. The raw material used can be modified according to application characteristics or special conditions.

GLUED-IN GASKETS

UG068
20 x 14

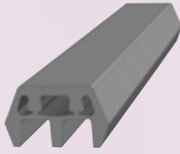

UG025
26 x 17

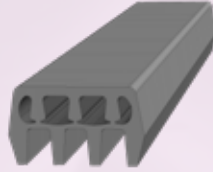

UG022
29 x 14

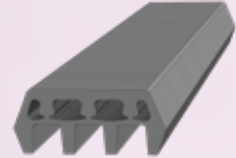

UG004
33 x 12

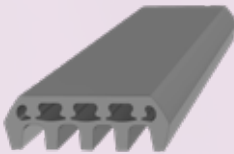

UG026
33 x 14



UG013
33 x 16

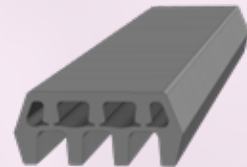

UG021
44 x 20

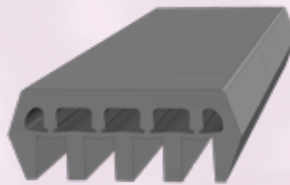

MIXED GLUED-IN GASKETS With Hydrophilic Barrier

UG028
26 x 17

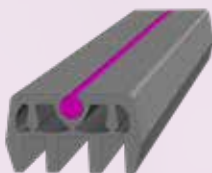

UG039
33 x 14

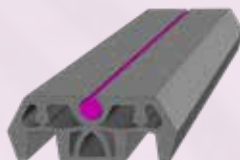

UG030
33 x 16

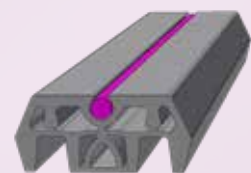

FAMA Special Gaskets

HYDROPHILIC GASKETS

STRIP



STRIP WITH RIBS



HYDROPHILIC CORD



SWELLING OF HYDROPHILIC MATERIAL OVER TIME
IN DEMINERALIZED WATER

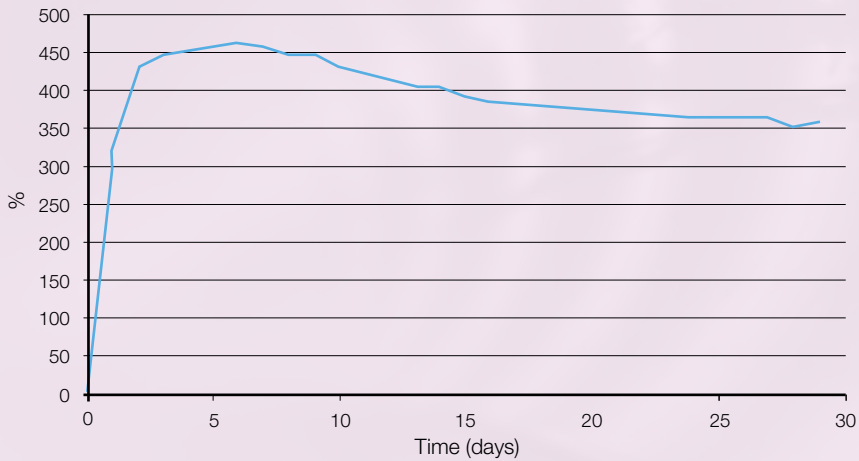

FAMA supplies a wide range of customizable hydrophilic gaskets conceived according to different functional techniques. The hydrophilic profile must be tested with ground water.

INTRUSIVE GASKET

For abnormal GAPS recovery

UG018F
29 x 14

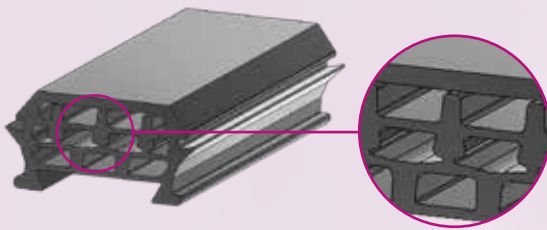

- Contact surface swelling can support abnormal GAPS
- Contact surface swelling can compress gaskets after segment installation, thus reducing sliding

FAKE GASKET FOR TRIAL RING

In place of anchored gasket

UG062
29 x 14

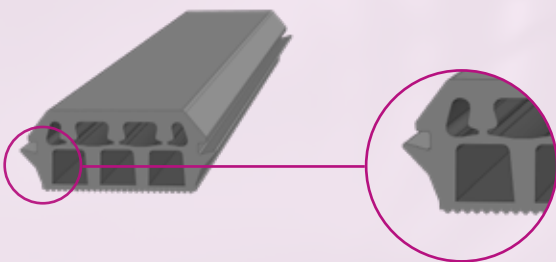

- The fake gasket is used in trial ring in place of anchored gasket

ASYMMETRIC GASKET

For high compression force

UG077
44 x 20

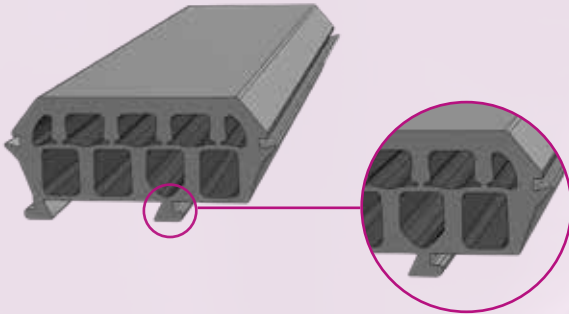

- The asymmetric solution is applied to a large gasket that could cause breakage because of the high compressive force
- The particular distance of the anchor foot of the eccentric gasket overcomes this risk of breakage

CHEMICAL PROTECTION SYSTEM

For the integration of a protective film on tunnel intrados

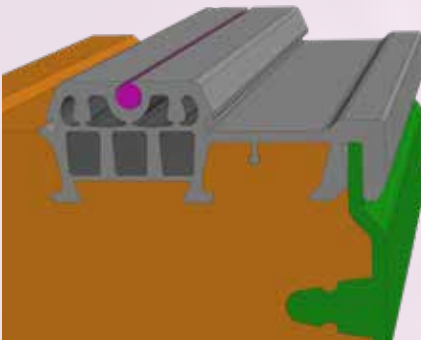

Sealing of joints with HDPE film is normally done by overlapping HDPE heat-sealed strips in place. The solution devised by FAMA makes it possible to eliminate this time-consuming and expensive operation by adopting a special gasket with multiple integrated solutions:

- The gasket is anchored to the concrete
- The gasket integrates the PVC film to itself, ensuring its sealing
- The gasket can integrate a hydrophilic cord, thus creating the second sealing barrier

GASKET PROTECTION SHIELD

For highly aggressive environments

UG043
32 x 14



The Gasket Protection Shield consists of two coupled profiles suitable for anchoring to concrete.

- The outer profile is manufactured from materials suitable for withstanding extreme situations
- The inner profile is produced from materials with high conservation of elastic energy

CROSS GASKET

With a double barrier

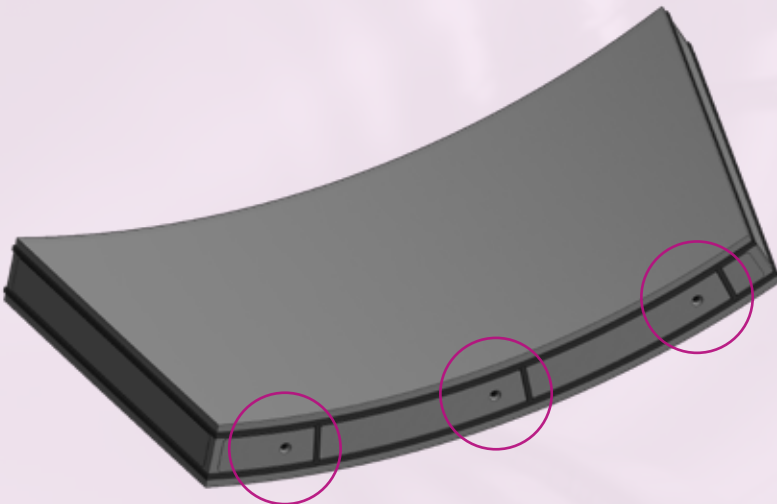

For projects where a double gasket is required at both the extrados and intrados, FAMA uses the anchored cross-gasket that prevents the propagation of any water infiltration inside the lining due to the channeling of the double gasket.

CONNECTION SYSTEMS AND ACCESSORIES

FAMA Connection Systems

Smartblock may have, in particular conditions, a side that can be screwed into the threaded socket

The female socket is manufactured in a unique shape with high-performance concrete anchorage geometry

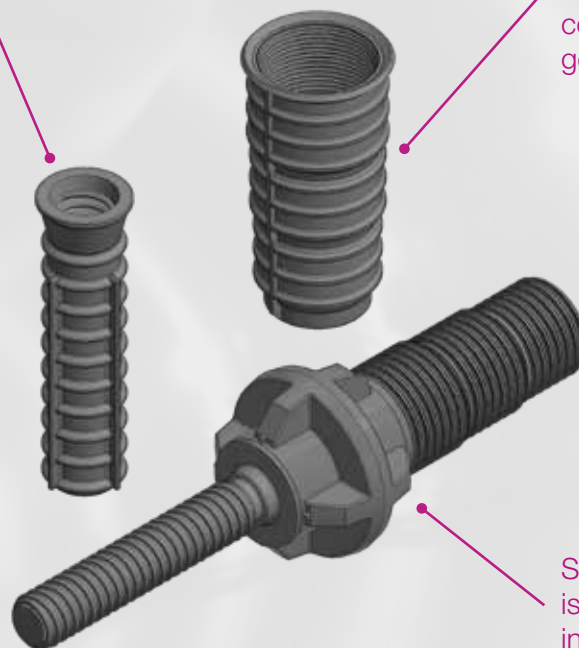

Smartblock connector is highly customizable in size and performance

FAMA offers, besides gaskets, a complete range of accessories, and in particular connectors that represent the second vital step for a good sealing and an excellent installation of tunnel lining rings.

FAMA has a wide range of connectors that can be customized in size, shape and performance. FAMA provides detailed technical information on request.

Connector functions are:

- Speeding up the installation of the tunnel segment
- Ensuring segment suspension in cantilever
- Securing closed joints
- Ensuring well-aligned joints
- Preserving concrete integrity
- Ensuring a suitable performance in the concrete female interface of the connector

FAMA Heeled Tooth Technology

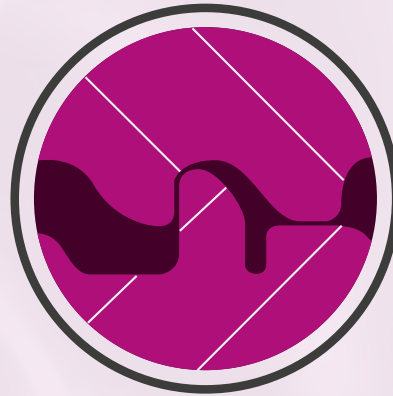
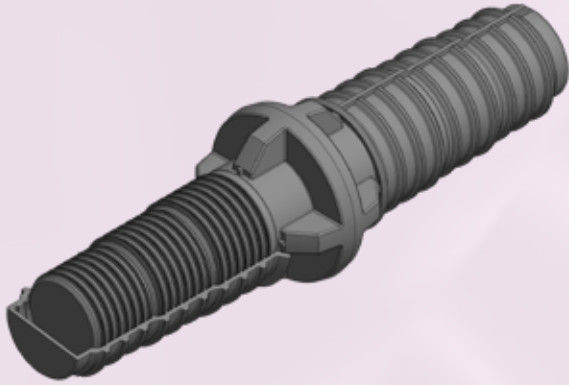

HEELED TOOTH

Collected GAP Data

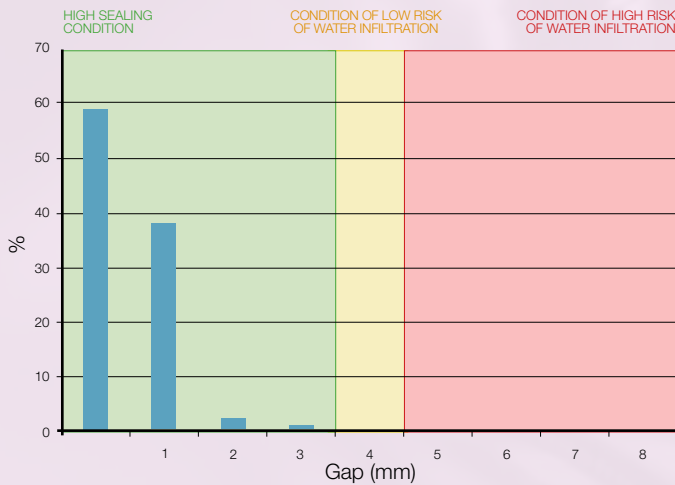

Collected OFFSET Data

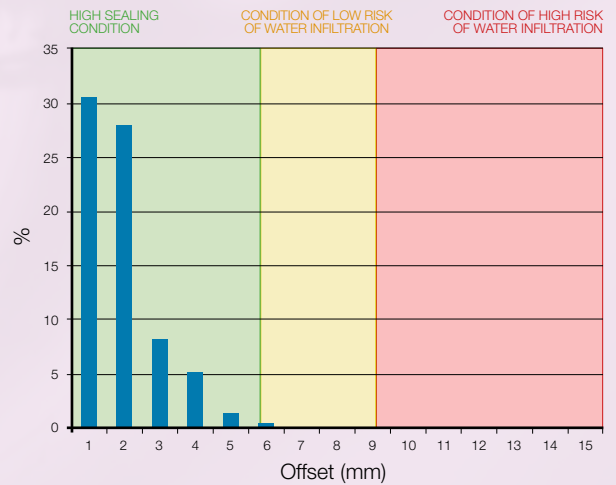

FAMA has conceived and realized a special and innovative design for its connectors. The heeled tooth came about after a thorough examination of existing products, identifying weak points and suggesting improvements. The FAMA connector has a gripping system that fits immediately without creating gaps. The female's tooth shape, the male's tooth shape, and the materials used protect the system against any misaligned insertions that often occur during the segment launching phase. Therefore, it can be safely said that this connection system offers greater

strength. The FAMA connector, in synergy with the third-generation gasket, provides excellent sealing results, significantly reducing infiltration. FAMA connectors have outstanding shear and pull-out performance and are manufactured to meet specific customer technical requirements. The range of FAMA connectors is integrated with special connectors used for specific requirements, with which Cross Passage, launch rings, test rings and more stand out.

SMARTBLOCK

SB 70-150 220-60



SB 50-100 250-60

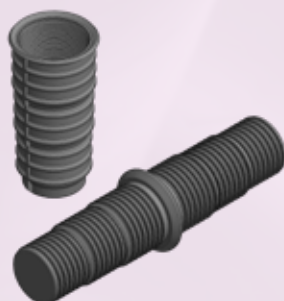

SB 70-90 300-50



SB 90-160 300-60

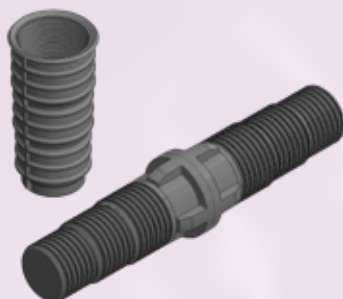

SB 90-180 300-80



SMARTBLOCK WITH BREAKAWAY

SB B 90-180 300-80



SB B HS 90-300 300-80



The exposed connectors represent the basic versions of each category from which the many performance variants required are derived.

SCREW SMARTBLOCK

SB 90-160 350-60



SB 90-180 350-80



SB HP 320-380 475-100



SB HP 170-80 430-95



SCREW SMARTBLOCK WITH BREAKAWAY

SB B HS 90-180 350-80



SB B HS 90-300 350-80



The exposed connectors represent the basic versions of each category from which the many performance variants required are derived.

SMARTBLOCK HS - CROSS PASSAGE

HS 130-300 300-80

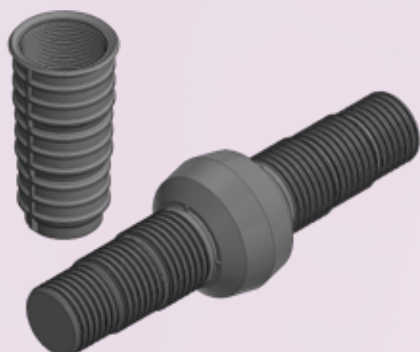

HS 80-500 330-95

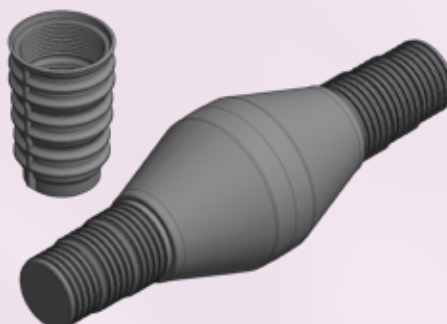

SMARTBLOCK FOR LAUNCHING RING

SEMI SMARTBLOCK
WITH INTERNAL THREAD

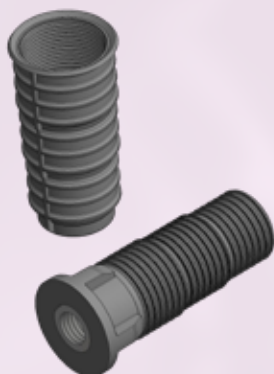

SEMI SCREW SMARTBLOCK

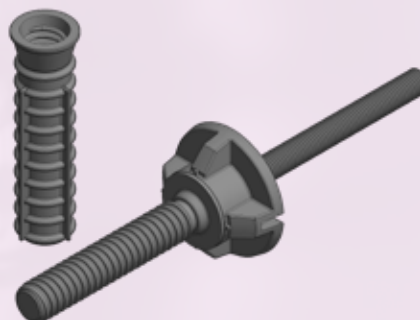

SMARTBLOCK FOR REMOVABLE SEGMENTS

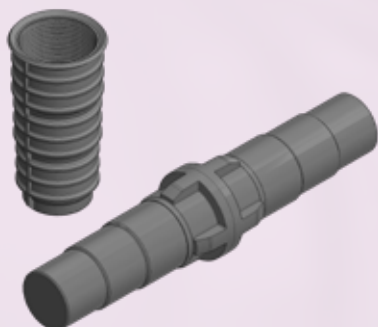

SMARTBLOCK SELF-PROTECTED AGAINST AGGRESSIVE AGENTS

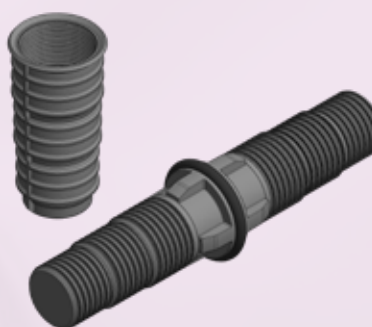

DEMOLDING FACILITATOR



CENTERING PINS

CENTERING PIN 80-65

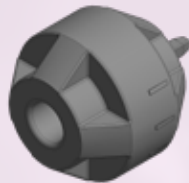

CENTERING PIN 90-50



CENTERING PIN 180-60

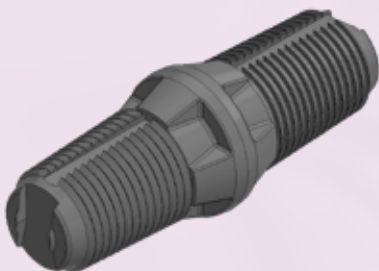

CENTERING PIN 230-95

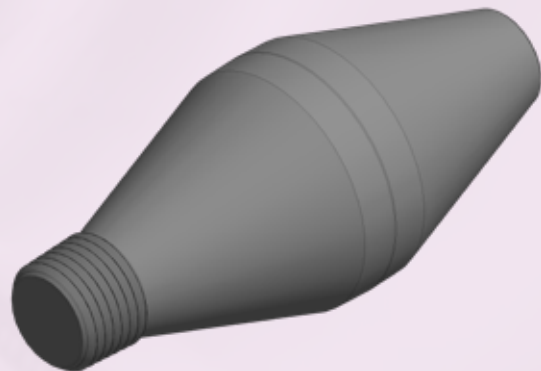

FAMA centering pins are designed to perform different functions which determine their dimensions and characteristics. A full range of devices is available and customizable.

GROUTING AND LIFTING SYSTEMS

LIFTING SOCKET D44

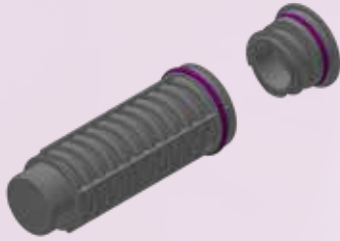

LIFTING AND GROUTING SOCKET D48

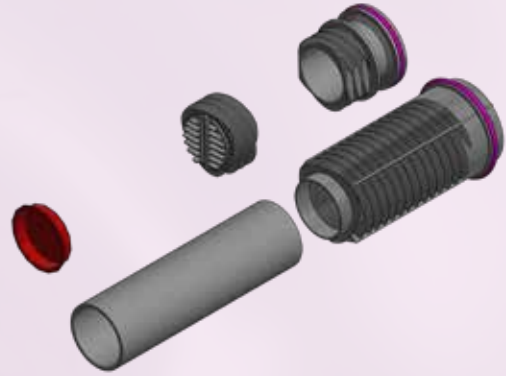

GROUTING SOCKET D50



GROUTING SOCKET D90



SAFETY PIN

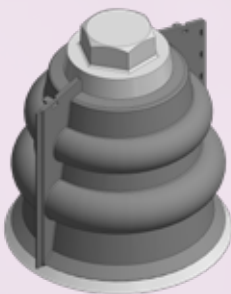

ANTI-UNSCREWING PLUG FOR GROUTING SOCKET



ANTI-UNSCREWING RING NUT FOR DRAINAGE

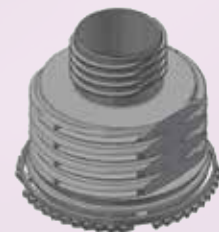

Grouting and lifting systems are designed and manufactured for any size of segment and can be customized to the customer's specific technical requirements.

GROUTING AND LIFTING SYSTEMS WITH BREAKAWAY

GROUTING SOCKET D48

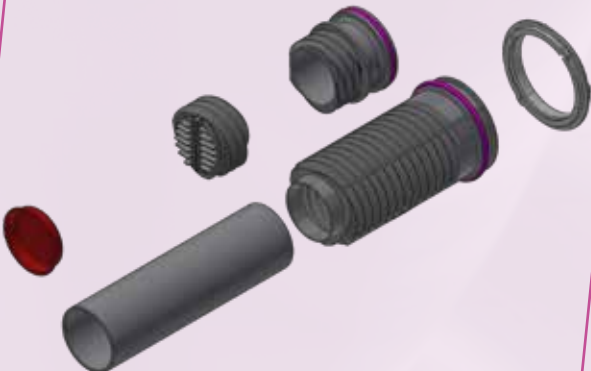

GROUTING SOCKET D50



QUICK COUPLING
GROUTING SOCKET D75

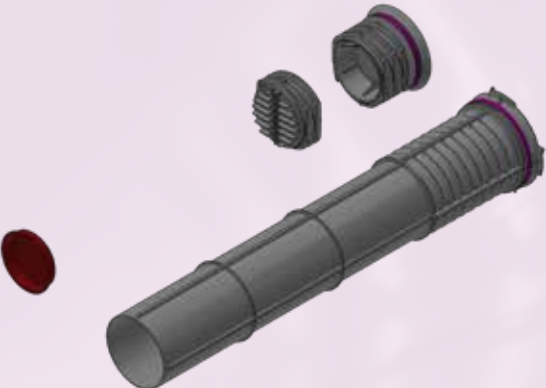

GROUTING SOCKET D90

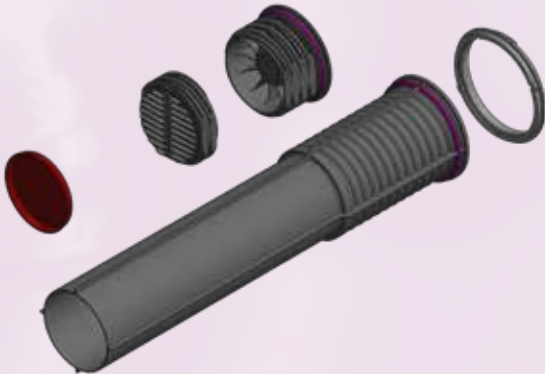

EASY REMOVABLE SEALING SYSTEM
FOR GROUTING SOCKET



DEEPER CAP

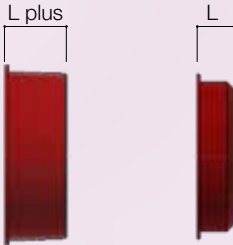

THREADED SOCKETS DIN 405

THREADED SOCKET
T19 × 100

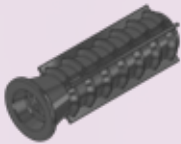

THREADED SOCKET
T25 × 120



THREADED SOCKET
T25 × 140

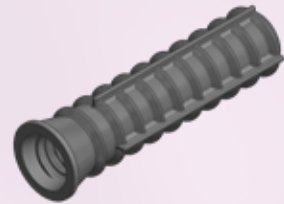

THREADED SOCKET
T25 × 170

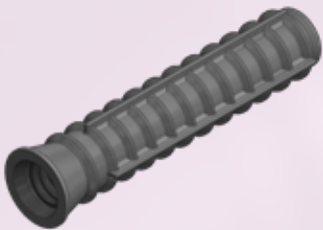

THREADED SOCKET
T28 × 160

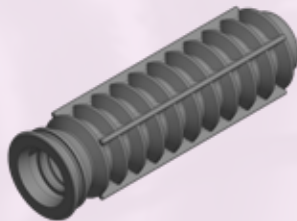

THREADED SOCKET
T32 × 200



BREAKAWAY SOCKETS

ANODE RING



ANODE COLLAR



ANODE SECTORS

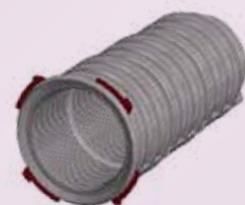

BREAKAWAY THREADED SOCKETS DIN 405

BREAKAWAY
THREADED SOCKET
T19 × 100

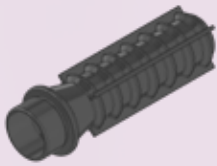

BREAKAWAY
THREADED SOCKET
T25 × 120



BREAKAWAY
THREADED SOCKET
T25 × 140



BREAKAWAY
THREADED SOCKET
T25 × 170



BREAKAWAY
THREADED SOCKET
T28 × 160



BREAKAWAY
THREADED SOCKET
T28 × 200



BREAKAWAY
THREADED SOCKET
T32 × 200



SOCKETS WITH METRIC THREAD ISO 261

THREADED
SOCKET M10x85

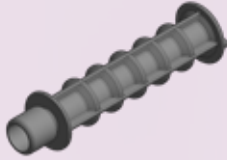

THREADED
SOCKET M12x85

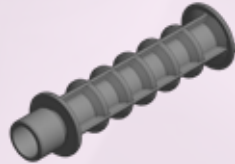

THREADED
SOCKET M16x105

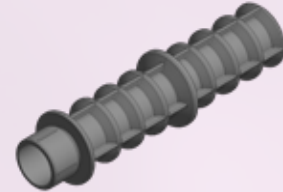

THREADED
SOCKET M24x110

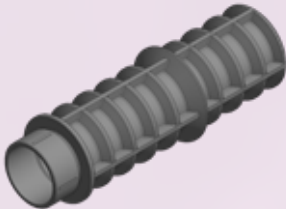

THREADED
SOCKET M24x125

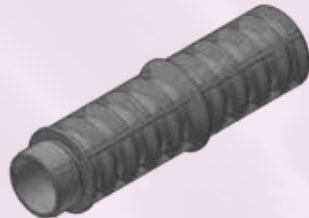

THREADED
SOCKET M30x200

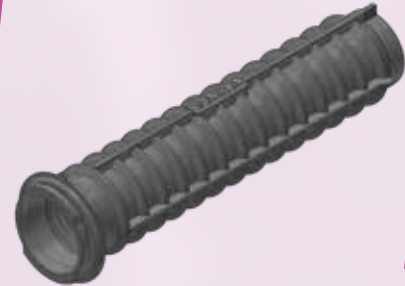

RAIL SOCKET
T20x135

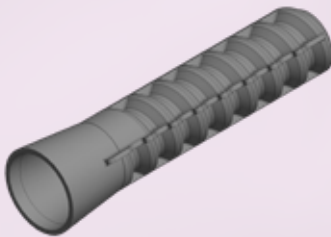

STAINLESS STEEL
FERRULE



SOCKET WITH METRIC
THREAD FOR INJECTIONS



BREAKAWAY PLUG
FOR SOCKET
WITH METRICAL THREAD



SEALING PLUG

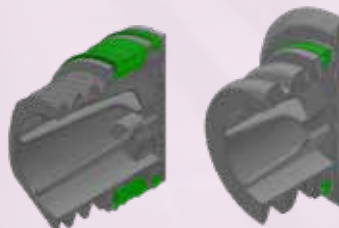

BOLTS AND WASHERS



Fastening systems with bolts and washers are used on the radial and circumferential joints of the lining segments in the tunnel; they increase shear and pull-out resistance on the connecting joints. A complete range of bolts coupled with FAMA threaded sockets withstand tensile stresses from 70 to 400 kN.

- The length of the bolt fits design specification
- The thread length on the bolts ranges from 115 to 155 mm according to socket type
- Bolts are available in different diameters (20/25/28 mm)
- The thread pitch ranges from 5 mm to 12.5 mm (rail bolts)
- The bolts are made of C40/C45 steel and, at the customer's request, also of 316L stainless steel or any other grade
- FAMA fasteners are available in different strength grades (ASTM A325, 10.9, 12.9)

When they can be removed, the bolts and washers are supplied raw or electrolytically galvanized while permanent bolts are treated with the hot-dip galvanizing process or made of stainless steel. Additional accessories such as HDPE washers, washers with grommet and plain grommets are also available in the range.

SPECIAL BOLTS



Bolts for the adjustment of precast slabs

GUIDING RODS

GUIDING ROD WITH CLIP

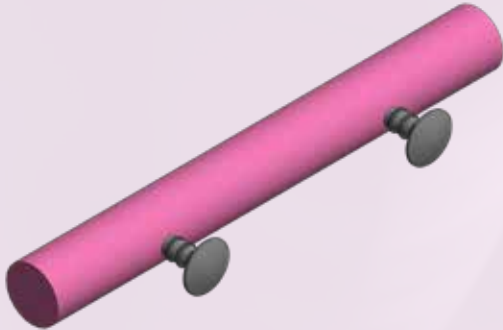

-45° BLUNT GUIDING ROD



GUIDING ROD WITH SCREW

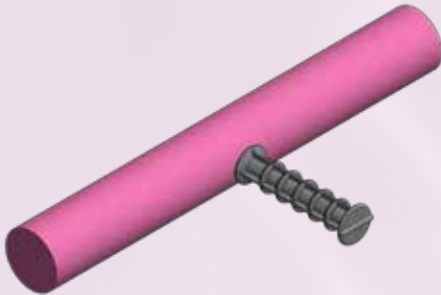

GUIDING ROD WITH HOLE

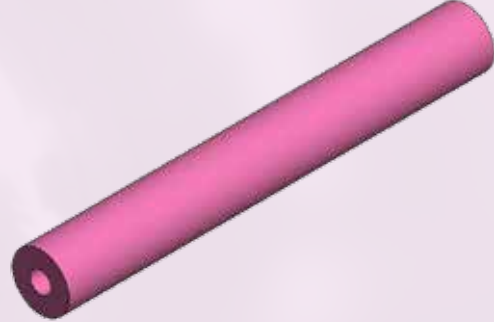

FILLED GUIDING ROD

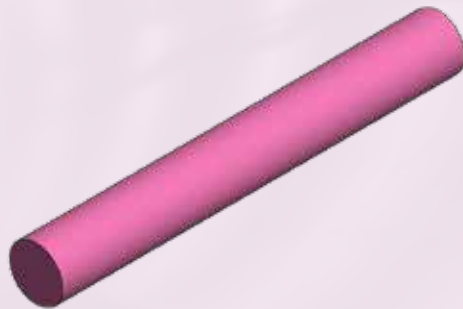

Guiding rods functions are:

- Allowing correct positioning and longitudinal alignment of segments
- Reducing the risk of segment damage during installation
- Increasing shear resistance between segments of the same ring
- Reducing offset between segments minimizing leakage risks

FAMA guiding rods are available with requested diameter and length dimensions and are produced using recycled materials.

LOAD-SHARING CUSHIONS

BITUMINOUS STANDARD
OR SELF-ADHESIVE PACKER



WOOD PACKER



FAMA packers are used to avoid cracking and breakage of the segments because of load concentrations.

Load-sharing cushions are usually installed on the circumferential side of the segment.

The shape and dimensions of the load-sharing cushions are designed for each specific tunnel segment.

Load-sharing cushions are available in different materials according to customer technical specifications.

PRECASTING

FAMA Sizes and Designs Precast Plants

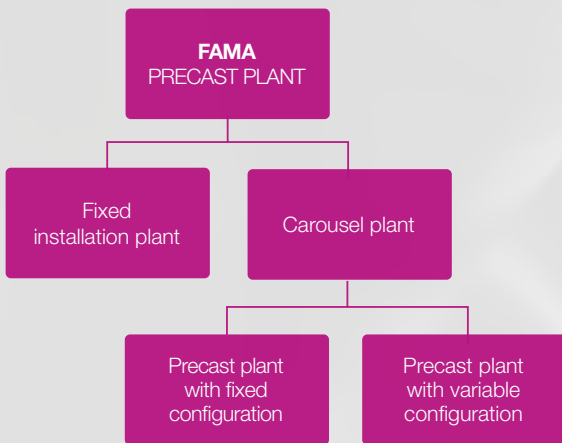

TBM requirement plan, production, carousel and storage

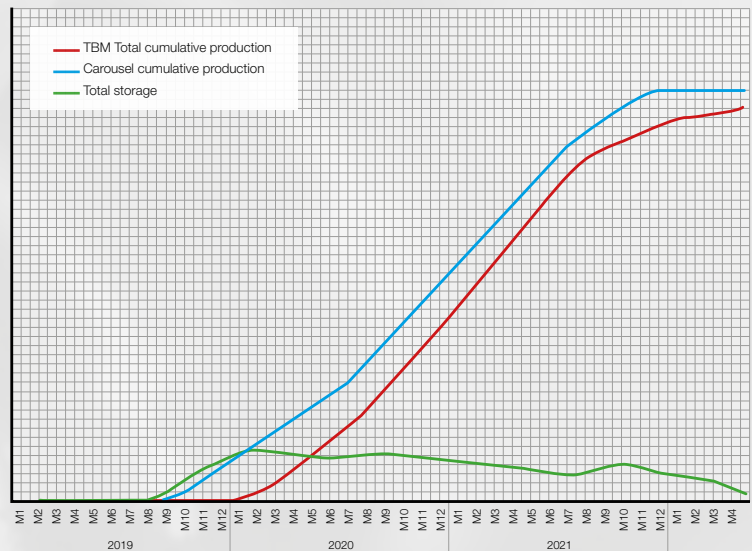

TBM absorption chart, production, carousel and storage. The TBM absorption chart is structured according to progress plans and dimensions strategic stocks.

- FAMA plant for segments includes formworks both in fixed or carousel configuration
- FAMA designs and manufactures formwork that can be installed on any existing carousel plant with full integration of operational functions and dimensional conditions
- FAMA formwork is designed and tested to operate with fiber concrete, ensuring its excellent distribution within the formwork due to perfectly designed and dimensioned vibration system

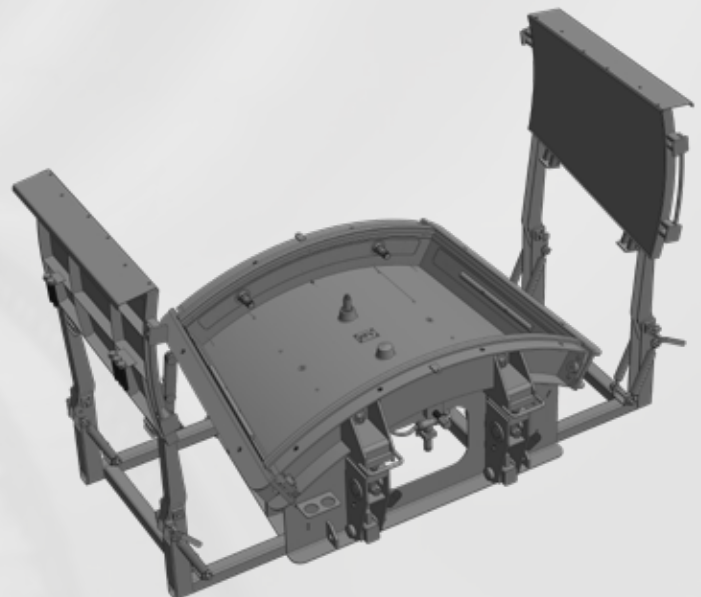

FAMA has the Expertise to Produce Formworks of the Highest Quality and Ergonomics

The study aims to plan tunnel lining precasting, determining:

- Precast plant productivity
- Precast plant layout
- Sizing of the prefabrication
- Guarantee of continuous supply of segments to the TBM, according to schedule

The study of the plant ensures technical coordination with the accessories used, guaranteeing the client an optimal result.

CAROUSEL STRUCTURAL DEFINITION

RING CHARACTERISTICS									RINGS SETS			
ø extrados [m]	ø intrados [m]	Average width [m]	No. segments / ring	Ring volume [m ³]	Formworks set weight ~[kg]	Average segment volume [m ³]	Maximum segment volume [m ³]	No. total rings	No. formworks	No. sets formworks	Transfer formworks	No. total formworks in the carousel
9,6	8,5	2	8	31,3	40000	4	-	1000	48	6	0	48
CAROUSEL CHARACTERISTICS												
No. assembly lines	No. formworks on assembly line	No. aging lines	No. formworks on aging line	No. formworks in translation	No. of position between casting chamber and aging chamber	No. total positions in the carousel	No. formworks in aging chamber	Average no. rings in aging chamber	Concrete volume in aging chamber ~[m ³]	Concrete weight in aging chamber ~[kg]	Mold weight in aging chamber ~[kg]	
1	11	3	12	1	3	48	36	4,5	140,7	337765	180000	
PRODUCTION										MONTHLY PRODUCTION		
Complete cycle time on assembly line [min]	No. shift / day	No. hours / shift [hours]	Working hours per day	Cleaning maintenance hours per day (included in working hours)	Daily segment production	Aging time (From casting to demolding) [hours]	Time in curing chamber [hours]	RINGS/ DAY	M ³ concrete / day	Working days / month	M ³ concrete / day	Total ring / month
10,0	2	8	16	2	84,00	6,5	6,0	10,5	328,4	22	7224	231
ESTIMATION OF REQUIRED PERSONNEL ON ASSEMBLY LINE EACH SHIFT										INCIDENCE DIRECT LABOR COST		
Formwork opening	Formwork demolding	Formwork cleaning	Disarming distribution	Gasket mounting	Insertion cage and accessories	Formwork casting	Extrados finishing	Pre-storage and storage managing	Estimated workers on assembly line each shift	Incidence of direct labor on each segment [€ / segment]	Incidence of direct labor on m ³ of concrete [€ / m ³]	Total cost of the direct labor on the entire production [K€]
2	2	2	1	1	2	1	2	1	14	67	17	533
ESTIMATED CONSUMPTIONS												
Estimated natural gas consumption [Nm ³ /h]	Estimated diesel consumption [Kg/h]	Estimated GPL consumption [Kg/h]	Diesel tank size (for one day consumption) [m ³]	GPL tank size (for one day consumption) [m ³]	Temperature increasing per hour in the aging chamber [°C/hour]	Maximum temperature in aging chamber [°C]	Aging chamber heat request per hour [Kcal/hour] (+12% for thermal dissipation)	Steam generator size (kg steam/h @ 12 bar)	Total concrete volume	Reinforcement cage weight each m ³ of concrete	Total reinforcement cage weight	
34,3	27,9	26,1	0,5	0,8	15	50	1894983	3158	31.275	90	2.814.710	

On the basis of the TBM's advancement requirements, FAMA has designed a parametric system of plant dimensioning to identify the different configurations which had been evaluated during the preliminary study in order to better support and address the client.

FAMA Designs Plants for Carousel and Fixed Formworks

FAMA designs fixed and carousel formwork systems in-house with its own technicians. The first step in formwork design is the creation of a 3D model and a specific structural analysis (FEM) to assess the loads to which the formwork is subjected

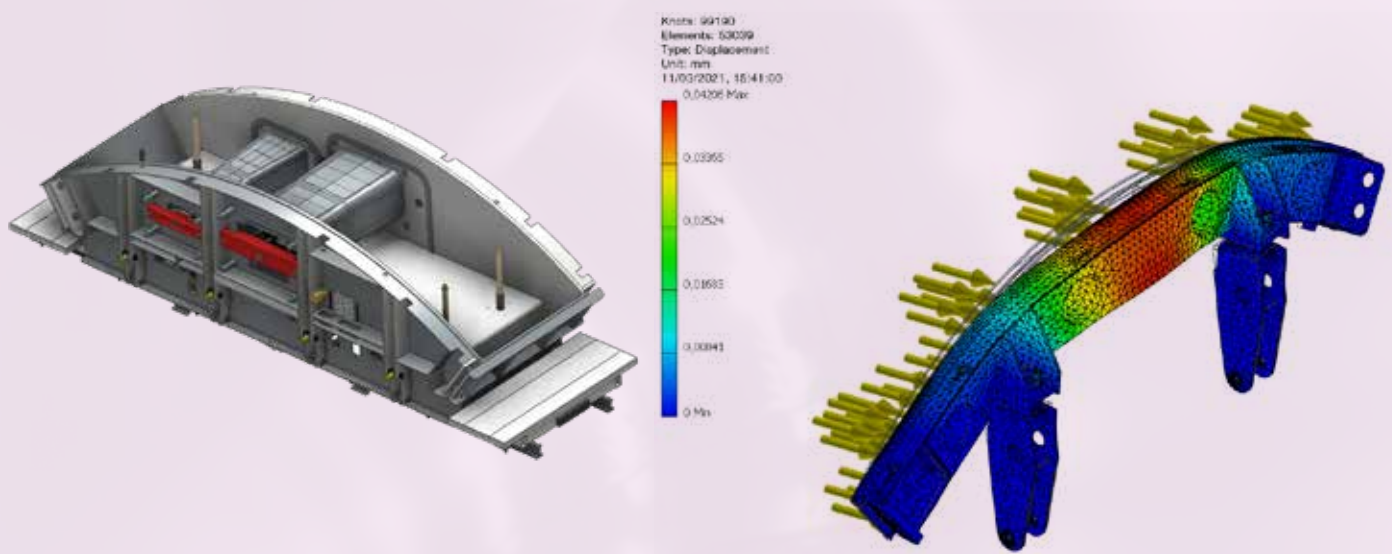

Particular emphasis is placed on the safety and ergonomics of the workstation in order to facilitate the operator's activities with a consequent increase in efficiency and reduction of scraps or defects on the segment.

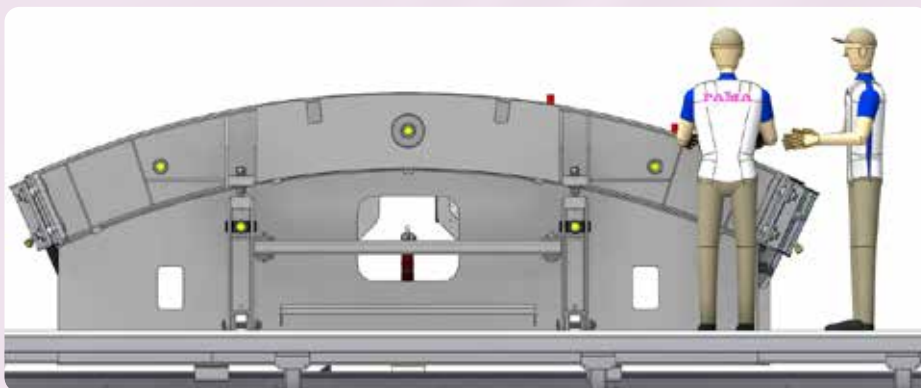

FAMA selects Italian manufacturers that can boast many years of experience in equipment manufacturing.

MECHANICAL SUPPORTS FOR BREAKAWAY ACCESSORIES

**BREAKAWAY THREADED SOCKET
SUPPORT FOR LONGITUDINAL JOINT**



**BREAKAWAY THREADED SOCKET
SUPPORT FOR SCREW SMARTBLOCK B**

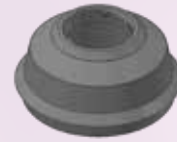

**REMOVABLE PLUG FOR BREAKAWAY
GROUTING SOCKET SUPPORT**

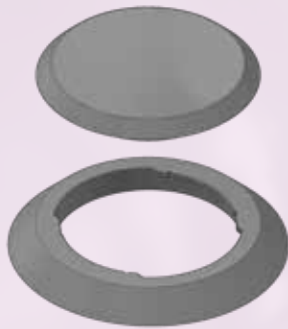

**SUPPORT FOR BREAKAWAY
GROUTING SOCKET**



**SUPPORT FOR QUICK
COUPLING GROUTING SOCKET**



**SUPPORT FOR QUICK
COUPLING SOCKET**

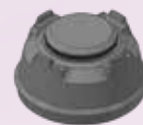

FORMWORK AND PLANTS

FORMWORK
WITH AUTOMATIC COVERS
FOR CAROUSEL

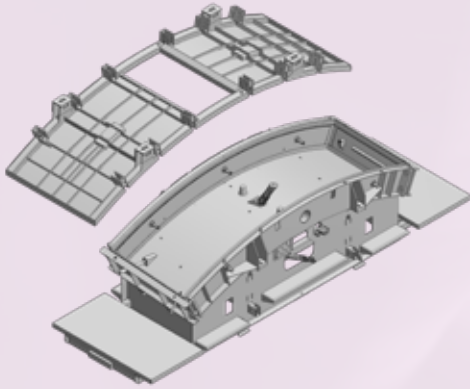

FOLDABLE COVERS

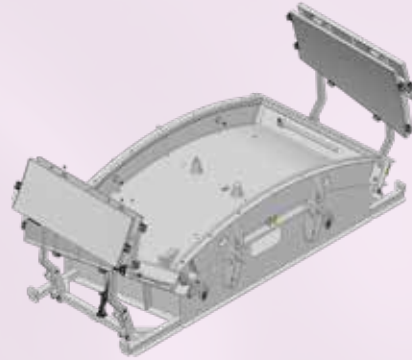

HYBRID FORMWORK

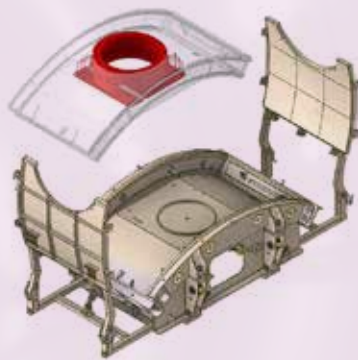

STATIONARY FORMWORK PLANT

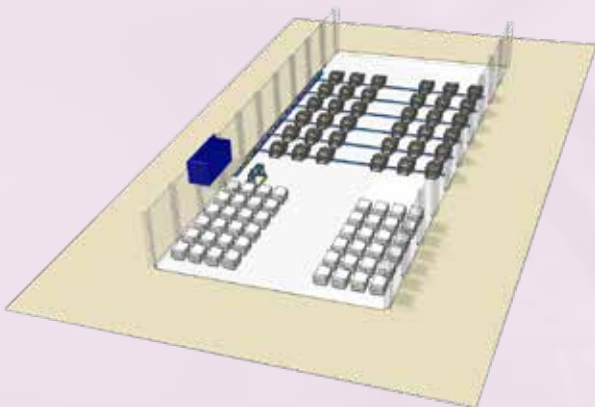

CAROUSEL PLANT

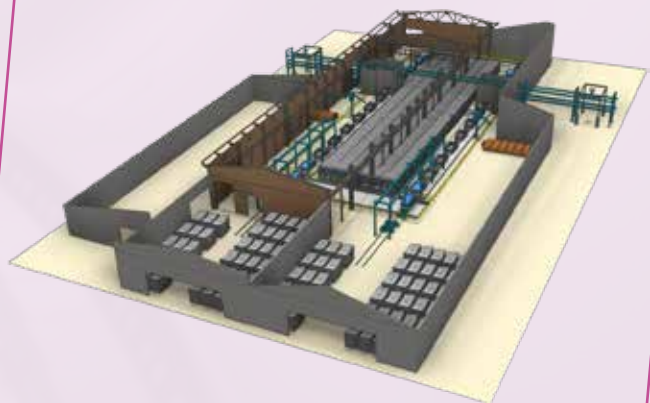

PRECAST EQUIPMENT

CAROUSEL EQUIPMENT

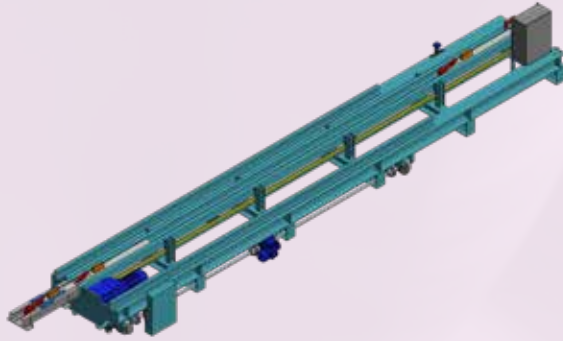

CAGE TRANSPORT BELT

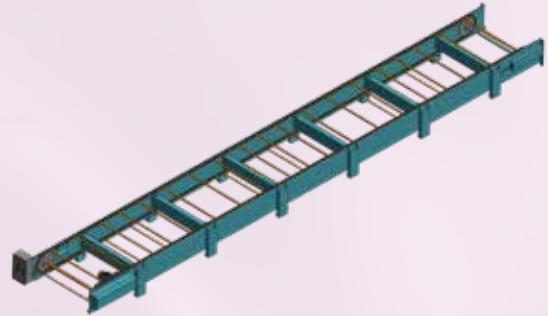

DEMOLDING AND TILTING DEVICE

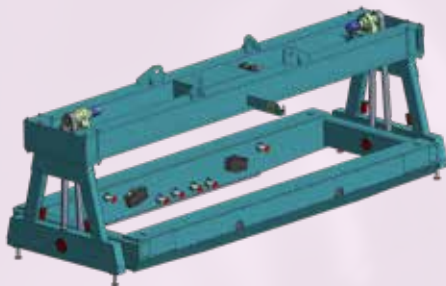

TRANSFER WAGON

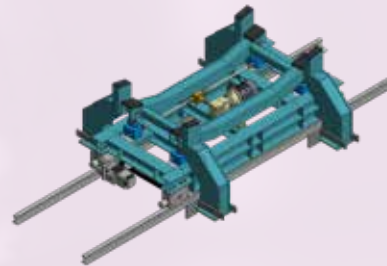

HYDRAULIC CLAMP

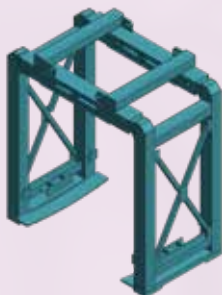

MECHANICAL CLAMP



SPECIAL DEVICES

**FORMWORK GROOVE
CLEANER**



**HYDROPHILIC CORD
INSERTER DEVICE**



**LIFTING BALL
FOR SEGMENT ERECTOR**



**PEA GRAVEL
INJECTION NOZZLE**

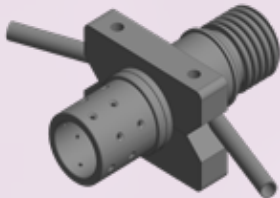

RAIL SOCKET SUPPORT

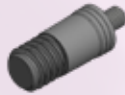

**SCREW TOOL
FOR GROUTING SOCKET
PLUG D48-D50**



**SCREW TOOL
FOR GROUTING
SOCKET PLUG D90**



**SCREW TOOL
FOR NO-RETURN
VALVE**



**SCREW TOOL
FOR SCREW
SMARTBLOCK**



**SPECIAL HAMMER
FOR ANCHORED GASKET
INSTALLATION**



**TBM ENTRANCE GASKET
FOR THE SEALING OF THE
FIRST TUNNEL RING**

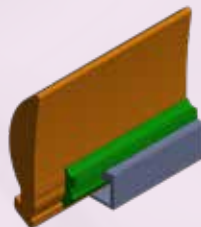

**EXTRACTOR IMPACT WRENCHES FOR
SEGMENT MECHANICAL ELEMENTS**



**GLUE DISPENSER
FOR GUIDING ROD**



**THREADED TWO-COMPONENT
INJECTION DEVICE**



**THREADED DEVICE
FOR GROUTING SOCKET THREAD
PROTECTION**



**GLUE DISPENSER
FOR GASKET**



TECHNICAL COGENERATION

Sharing Skills and a Propensity for Innovation

FAMA has a wealth of competence and excellence and an attitude to innovation recognized and appreciated by the best global players.

ANTI-SEISMIC DEVICE

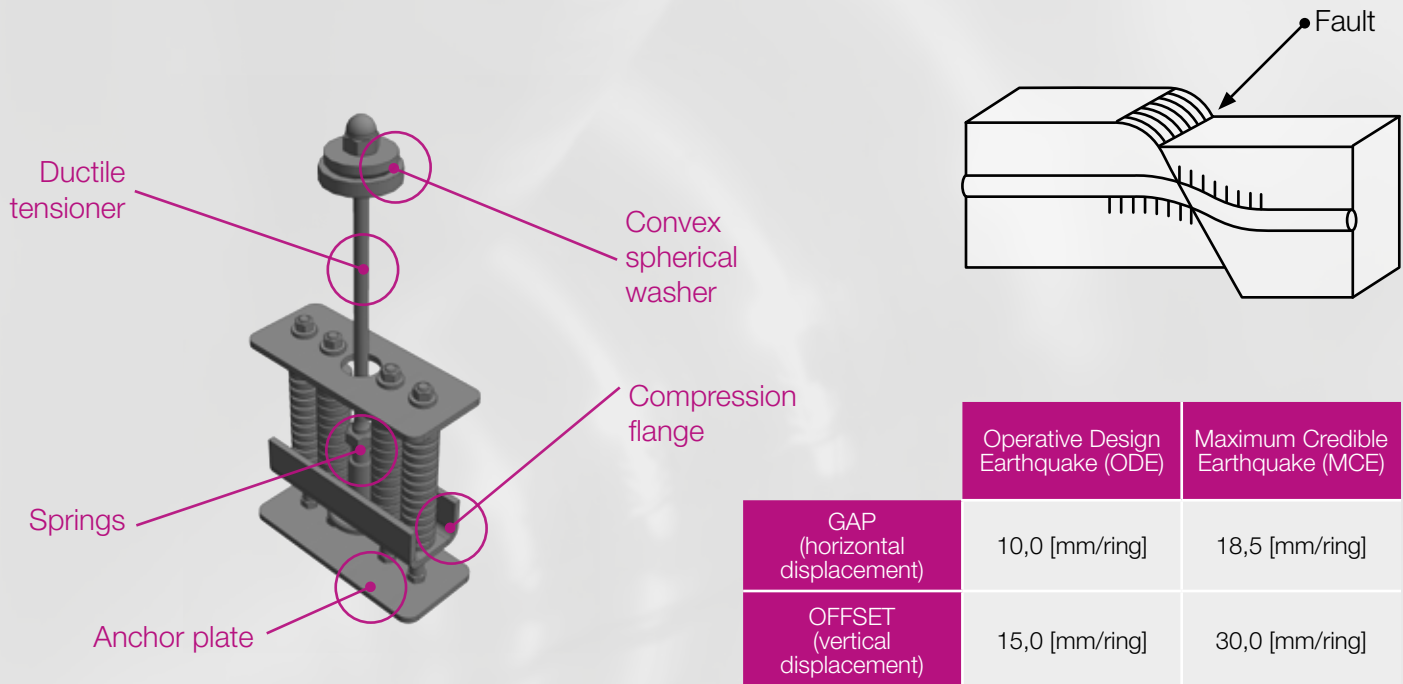

	Operative Design Earthquake (ODE)	Maximum Credible Earthquake (MCE)
GAP (horizontal displacement)	10,0 [mm/ring]	18,5 [mm/ring]
OFFSET (vertical displacement)	15,0 [mm/ring]	30,0 [mm/ring]

FAMA anti-seismic device was installed for the first time in 2016 in the metro project of Thessaloniki, in Greece. It was officially presented at WTC 2017 in Bergen (Norway).

The anti-seismic device ensures the tunnel rings connection and support its displacement in case of a seismic event, within the maximum technical design limits provided by seismological analysis.

The special anti-seismic device features are:

- A metal spring part suitable for absorbing displacements between contiguous rings
- A ductile rod to increase the overall deformability of the system
- The system is easy to install
- The installation of the device in the segment does not significantly alter its normal preparation steps
- The devices, for the preparations in the segment suitable for receiving the system, can be installed in the pre-existing formwork
- The modification of the formwork is reversible

CRACK INDUCER

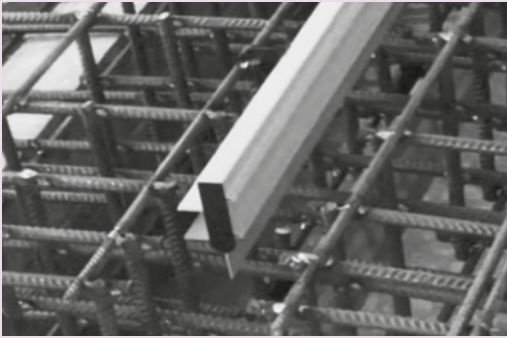

Crack inducer it is a device produced in plastic material designed to be easily and quickly fixed to the segment reinforcement cage prior to its positioning in the formwork and then be incorporated into the finished segment.

The purpose of the crack inducer is to cause controlled cracking in the segment concrete by generating weakened areas in the segment section at a specific location.

In this way it helps to avoid cracks in the concrete in areas of the segment considered critical.

The crack inducer is equipped with a position adjustment system to ensure alignment with the intrados and extrados surface of the segment

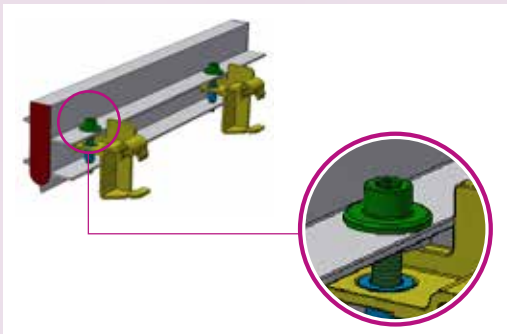

PROTEX INNOVATIVE SOLUTION FOR SEWER TUNNEL

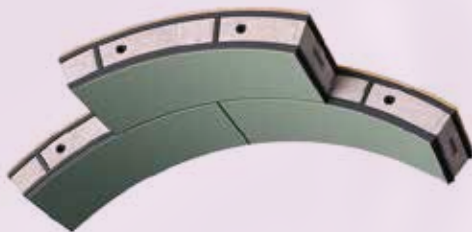

PROTEX
System



FAMA has committed to finding a solution that may counter the negative impact of contaminants and aggressive agents contained mostly in the tunnels for drainage of urban water and wastewater.

FAMA has therefore designed and developed PROTEX which is an innovative system for the protection of the segment and hydraulic sealing of tunnels in contaminated environments.

The system consists of an HDPE layer on the segment intrados which is integrated to the anchored sealing gasket, thus providing a complete protection and sealing of the segments also along the joints.

PROTEX also includes a sealing gasket positioned on the extrados which provides, with the gasket positioned on the intrados, a double sealing level and prevents the risk of the surrounding soil erosion in the long term.

The use of the double sealing includes the adoption of a cross-gasket to confine infiltrations. This represents a further innovation as the cross-gasket is anchored to the concrete as well.

At last, the extrados surface of the segment is protected against external agents by a coating treatment. PROTEX is an innovative solution consisting of five levels of sealing

that allows completion of the tunnel lining during the installation phase, eliminating all the laborious secondary activities performed until now in the tunnel to obtain its sealing. At the same time, costs and construction time are reduced in the short and long term.

The durability of the work is thus ensured through the protection of the concrete and hydraulic sealing from inside and outside of the tunnel.

Technical Support Documentation

SUPPLEMENT FOR PRODUCTS

FAMA usually supplies a series of technical documents produced according to the current rules or on specific customer requests:

- PRECISE ANALYSIS OF PRODUCTS TECHNICAL CHARACTERISTICS
- QUALITY ASSURANCE PLAN
- PRODUCT TECHNICAL DATA SHEETS
- TECHNICAL REPORTS OF VALIDATION TESTS
- PRODUCT DRAWINGS
- GASKET AND ACCESSORIES INSTALLATION MANUAL
- CASE HISTORY

SUPPLEMENT FOR PROJECTS

FAMA usually supplies a series of technical documents produced according to the current rules or on specific customer requests:

- TECHNICAL REPORT – STUDY OF FEASIBILITY
- GANTT
- QUALITY ASSURANCE PLAN
- SAFETY AND ENVIRONMENTAL PROCEDURES MANUAL
- FORMWORK DIMENSIONAL CONTROL MANUAL (MCE)
- VALIDATION REPORT
- INSTALLATION MANUALS
- OPERATION AND MAINTENANCE MANUALS

THE DOCUMENTATION COULD BE TRANSLATED INTO THE REQUESTED LANGUAGE.

SPECIAL SERVICES

- Professional support to engineering services in the technical selection of products and their use (technical calculation reports, plant sizing and layout, study of new products and related validation tests).
- Fitting test at site start-up: FAMA employs augmented reality technology to overcome travel limitations thus reducing consumption and ensuring continuous support.
- On-site start-up assistance: FAMA provides the technical support needed to train personnel using its accessories and gaskets, thus minimizing any errors.
- Measurement of test rings, formwork and segments at the customer's request:
 - FAMA uses laser tracker and laser scanner technology for timely dimensional surveying;
 - FAMA performs, at the customer's request, trial ring preparation at its workshops or directly on site.



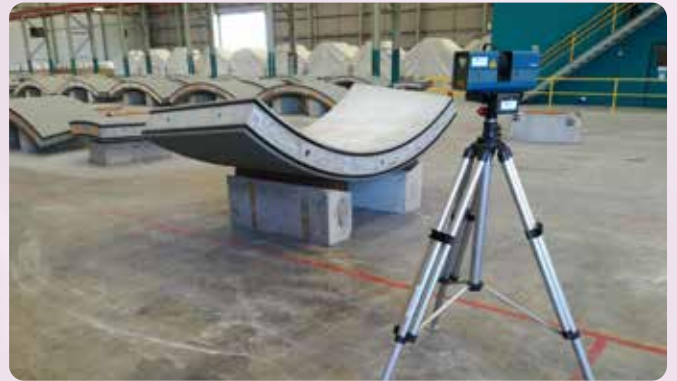

SCIENTIFIC COLLABORATIONS



CERTIFICATIONS AND ASSOCIATIONS



Member of German
Tunnelling Association



Member of French
Tunnelling and Underground
Space Association



Member of General
Confederation
of Italian Industry



Member of Italian
Tunnelling Society



A Company
Supporter of



FAMA

HIGH INTENSITY OF INNOVATION

CONCEPT

TECHNICAL CO-GENERATION

DESIGN AND DEVELOPMENT

TEST AND QUALIFICATION

PRODUCTION AND DIRECT SALE

SUPPORT AND ASSISTANCE



Reputation | Competitiveness | Skills